

KEAN UNIVERSITY

Material Service Stationery Catalog

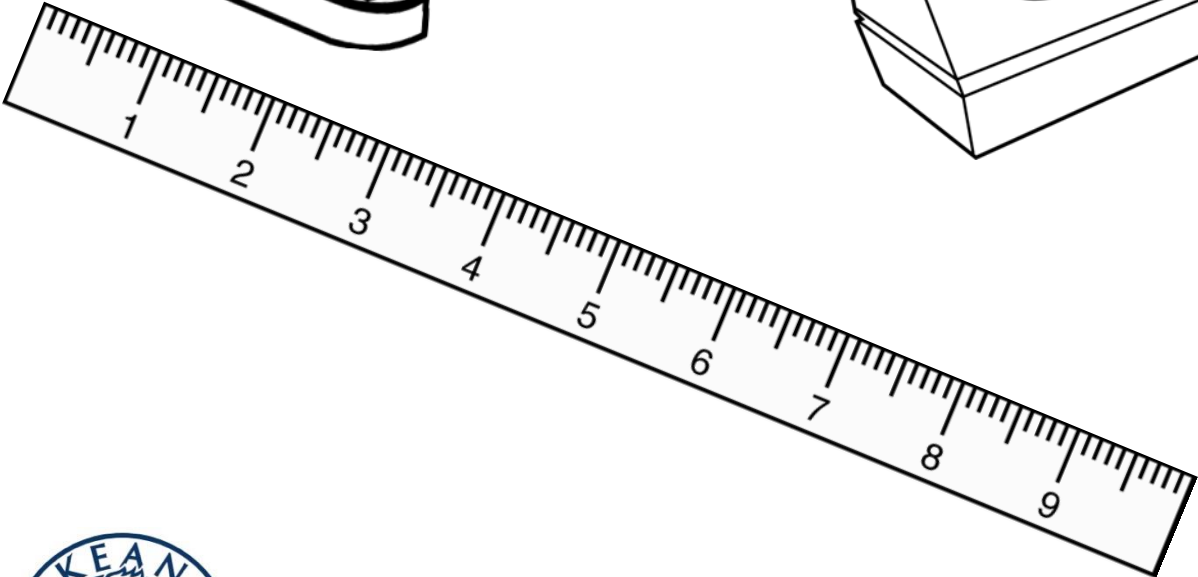
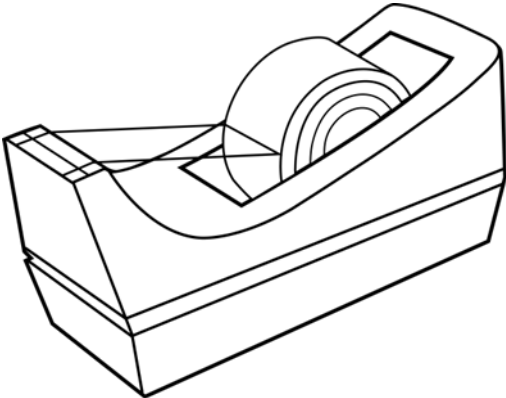
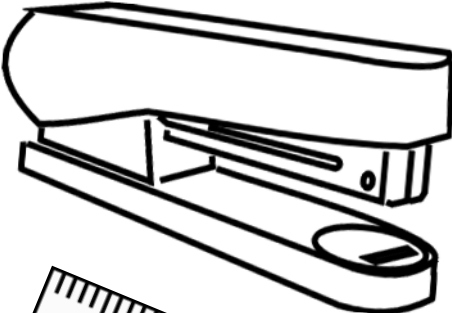

KEAN
UNIVERSITY

MATERIEL SERVICES STATIONERY CATALOG

This Catalog provides faculty and staff with a listing of the most commonly used office supplies. To obtain merchandise in this catalog, a department must use a stationery supply form:

1. Stationery Supplies Requisition (see sample)

Complete:

- a. Date
- b. Cost Center Number including the object fund
- c. Department Name
- d. Location
- e. Phone Extension
- f. Stock Number
- g. Full Description (From *Catalog*)
- h. Quantity Ordered (Check **UNIT OF ISSUE** *see Catalog*)
- i. Sign By Cost Center Director

Mail to: **MATERIEL SERVICES**, Maintenance Building Room M135

MISSING INFORMATION AND ORDERING NOT FOLLOWING ABOVE GUIDELINES MAY CAUSE DELAYS IN THE DELIVERY OF THE ORDER.

Prices listed in this catalog as of 2020. However, they are subject to changing without notice. Orders are process as they come in within in five working days of receipt. *THERE ARE NO BACKORDERS. IN CERTAIN INSTANCES, SUBSTITUTION OF ITEMS ORDERED ARE MADE. QUANTTTES ORDERED AND RECEIVED MAY DIFFER DUE TO AVAILABILTY OF INVENTORY.* The catalog can change without notice for stock additional and deletions.

Over the counter service is available from 8:00am to 3:30pm

Monday through Friday (except Summer Hours)

If you have any questions with Stationery Catalog and Ordering Procedures please contact Materiel Services by calling 908-737-5080.

DEPARTMENT REFERENCE NUMBER
(Optional)



No. 999999

FOR MATERIEL SERVICES USE ONLY

KEAN
University

STATIONERY SUPPLIES REQUISITION

DATE * _____

COST CENTER * **999999**

DEPT. NAME * **Purchasing**

LOCATION * _____

EXTENSION * _____

DEPARTMENT USE ONLY

WAREHOUSE USE ONLY

ITEM NO.	STOCK NO.	DESCRIPTION	QUANTITY ORDERED	QUANTITY DELIVERED	UNIT OF ISSUE	UNIT COST	TOTAL COST
1.	15080	Duplication 8 /2 x 11	5 CS				
2.	12030	Kraft 9 x 12 **	50 EA				
3.	12035	Kraft 10 x 13 **	50 EA				
4.							
5.							
6.							
7.							
8.							
9.							
10.							

REMARKS:
 * Must be filled out by Department
 ** MUST be approved

NOTE: NO BACKORDER POLICY

* _____
 AUTHORIZED SIGNATURE

Most Commonly Ordered Materials:

<i>Stock No.</i>	<i>Item Description</i>	<i>Unit of Issue</i>	<i>Price</i>
19050	Book, Exam	Pack	\$ 8.36
19180	Clips, Gem Med (10 bxs/ct)	Count	\$ 7.37
13005	Folders, File Letter (100/bx)	Box	\$ 12.04
19426	Labels, Laser (1 x 2 5/8)	Box	\$40.09
15080	Paper, Duplicating 8 1/2 x 11 white	Case	\$31.98
16016	Pens, Medium Point (Black)	Dozens	\$ 2.86
16017	Pens, Medium Point (Blue)	Dozens	\$ 1.55
19570	Staples, Standard	Box	\$ 4.26

MATERIEL SERVICES STATIONERY CATALOG**A/B**

Stock No.	Item Description	Unit of Issue	Price
10010	Binders, 1" Cap 8 1/2 x 11 3 ring	Each	\$ 4.78
10015	Binders, 2" Cap 8 1/2 x 11 3 ring	Each	\$ 5.50
19045	Book, Class Record	Each	\$ 2.98
19050	Book, Exam	Pack	\$ 8.36
19275	Box, Banker Legal	Each	\$24.50
19270	Box, Banker Letter	Each	\$39.50
19080	Box, Moving	Each	\$ 2.52

C

Stock No.	Item Description	Unit of Issue	Price
19095	Calendar, Desk base	Each	\$ 8.46
19100	Calendar, Desk Refill	Each	\$ 7.98
19110	Calendar, National School (July-June)	Each	\$ 9.59
11005	Card, Index 3x5 (100)	Each	\$ 0.19
19155	Clips, Butterfly Large (12/bx)	Box	\$ 5.28
19160	Clips, Butterfly Medium (50/bx)	Box	\$ 1.32
19167	Cleaner for Dry Erase Boards	Each	\$11.79
19151	Clips, Binder Large	Box	\$ 5.70
19152	Clips, Binder Medium	Box	\$ 4.29
19150	Clips, Binders Small	Box	\$ 4.19
19180	Clips, Medium Gem (10 bxs/ct)	Count	\$ 6.82
19181	Clips, Large Gem (100/bx)	Box	\$ 7.43

D/E

Stock No.	Item Description	Unit of Issue	Price
19380	Dividers, 3 Ring (5/pks)	Pack	\$ 0.91
12020*	Envelopes, #9 Business Reply	Each	\$ 0.03
12010	Envelopes, #10 KU (500/bx)	Box	\$ 14.46
12045	Envelopes, # 10 KU w/ Widow (500/bx)	Box	\$ 32.23
12006	Envelopes, Interoffice Large (10x15)	Each	\$ 0.41
12005	Envelopes, Interoffice Small (100/pk)	Pack	\$ 10.62
12021	Envelopes, Kraft 6 x 9	Each	\$ 0.06
12030*	Envelopes, Kraft 9 x 12	Each	\$ 0.11
12035*	Envelopes, Kraft 10 x 13	Each	\$ 0.11
19225	Eraser, Chalkboard	Each	\$ 3.50
19230	Eraser, Dry Erase	Each	\$ 4.42

*Must be approved by Assistant Director of Purchasing

MATERIEL SERVICES STATIONERY CATALOG**F/G**

Stock No.	Item Description	Unit of Issue	Price
13010	Folders, File Legal (100/bx)	Box	\$ 22.29
13005	Folders, File Letter (100/bx)	Box	\$ 10.73
13020	Folders, Hanging Legal (25/bx)	Box	\$ 14.93
13015	Folders, Hanging Letter (25/bx)	Box	\$ 12.81
19520	Folders, KU 2 Pocket (Portfolio)	Each	\$ 0.62

H/I/J/K/L

Stock No.	Item Description	Unit of Issue	Price
19426	Labels, Laser (1 x 2 5/8)	Box	\$ 33.52
19460	Letter Opener	Each	\$ 2.04

M/N/O

Stock No.	Item Description	Unit of Issue	Price
19480	Markers, Broad Tip(Black)	Dozen	\$ 11.09
19497	Markers, Dry Erase Color Set(4 color set)	Set	\$ 12.71
19481	Markers, Dry Erase Black	Dozen	\$ 13.78
19482	Markers, Dry Eraser with Eraser	Dozen	\$ 17.92
19479	Markers, Highlighters (Yellow)	Dozen	\$ 9.78

P/Q

Stock No.	Item Description	Unit of Issue	Price
19060	Pads, Steno Book Gregg Rule (Narrow)	Each	\$ 1.39
19065	Pads, Steno Books Pitman Rule (Wide)	Each	\$ 2.21
14055	Pads, Telephone "While You Were Out"	Dozen	\$ 4.86
14010	Pads, White Ruled 5 x 8	Dozen	\$11.98
14022	Pads, White Ruled 8 1/2 x 11	Dozen	\$13.48
15065	Paper, Blue 8 1/2 x 11	Ream	\$ 3.92
15045	Paper, Canary 8 1/2 x 11	Ream	\$ 3.92
15060	Paper, Goldenrod 8 1/2 x 11	Ream	\$ 3.92
15050	Paper, Green 8 1/2 x 11	Ream	\$ 3.92

P/Q Continued

Stock No.	Item Description	Unit of Issue	Price
15055	Paper, Pink 8 1/2 x 11	Ream	\$ 3.92
15080	Paper, Duplicating 8 1/2 x 11 white	Case	\$ 31.98
15081	Paper, Duplicating 8 1/2 x 14 white	Ream	\$ 4.29
15082	Paper, Duplicating 8 1/2 x 17 white	Ream	\$ 6.35
15015	Paper, Letterhead	Ream	\$120.01
15090	Paper Towels	Case	\$ 16.04
19510	Pencils #2	Dozen	\$ 2.80
16030	Pens, Felt Fine Point (Black)	Dozen	\$ 14.98
16035	Pens, Felt Fine Point (Blue)	Dozen	\$ 14.01
16020	Pens, Felt Fine Point (Red)	Dozen	\$ 27.73
16005	Pens, Fine Point (Black)	Dozen	\$ 2.69
16015	Pens, Fine Point (Blue)	Dozen	\$ 2.29
16010	Pens, Fine Point (Red)	Dozen	\$ 2.07
16016	Pens, Medium Point (Black)	Dozen	\$ 2.54
16017	Pens, Medium Point (Blue)	Dozen	\$ 1.55
16018	Pens, Retractable Medium (Black)	Dozen	\$ 9.81
16019	Pens, Retractable Medium (Blue)	Dozen	\$ 5.05
14028	Post it (1 1/2 x 2)	Dozen	\$ 4.03
14026	Post it (3 x 3)	Dozen	\$ 9.78
14023	Post it (3 x 5)	Dozen	\$ 11.28
19525	Protector Sheets	Each	\$ 0.64
19535	Punch, Desktop 3 Whole Punch	Each	\$ 13.26

R

Stock No.	Item Description	Unit of Issue	Price
19545	Ruler 12"	Each	\$ 3.11
19550	Ruler 15"	Each	\$ 2.99

S

Stock No.	Item Description	Unit of Issue	Price
19560	Scissors	Each	\$ 8.56
19540	Staple Remover	Each	\$ 2.14
19595	Staplers, Standard	Each	\$ 6.07

S Continued

Stock No.	Item Description	Unit of Issue	Price
19600	Staplers, Heavy Duty	Each	\$ 20.31
19570	Staples, Standard	Box	\$ 4.28
19590	Staples, Heavy Duty 1/2	Box	\$ 6.59
19060	Steno Book, Gregg Rule (Narrow)	Each	\$ 1.39
19065	Steno Book, Pitman Rule (Wide)	Each	\$ 1.59
21130	Surge Protector 6 Outlets	Each	\$ 11.99

T/U/V

Stock No.	Item Description	Unit of Issue	Price
19605	Tabs, Hanging Folders	Box	\$ 3.79
18040	Tape, 2" Packing	Each	\$ 2.87
18005	Tape, Adding 2 1/4	Each	\$ 0.39
19218	Tape, Desk Top Dispenser	Each	\$ 5.62
19220	Tape, Hand Held Dispenser	Each	\$ 2.09
18025	Tape, Scotch Clear	Each	\$ 3.48
19635	Thumbtacks	Each	\$ 0.99
19284	Transparency (50/BX)	Box	\$ 18.72

W/X/Y/Z

Stock No.	Item Description	Unit of Issue	Price
19340	Whiteout Correction Fluid	Each	\$ 2.58